

two-point contact
两点接触

Overview

WF2547 is a 2.54mm pitch wire to board single and double row connectors, easy to assemble, can effectively ensure the stability of signal transmission and integrity, the board end provides horizontal and vertical mounting, to meet the customer's different angles of docking adaptation.

概述

WF2547是一款2.54mm间距线到板单排和双排连接器，组装简单方便，能有效确保信号传输的稳定性以及完整性，板端提供水平及垂直方向安装，满足客户不同角度对插适配。

Features and Benefits

- Misinsertion prevention design, effectively avoiding misinsertion
- Friction lock design to prevent accidental dislodgement
- Available in AWG#22 to 28 wire

产品特点

- 防错插设计、有效避免错插
- 摩擦锁设计，防止意外脱落
- 提供AWG#22~28线径

Product Applications

- Industrial equipment: automation equipment, robotics and control systems, control units
- Computers: motherboards, fans, hard drives, disk drives
- Household appliances: washing machines, refrigerators, ovens

应用领域

- 工业设备：自动化设备、机器人与控制系统、控制单元
- 计算机：主板、风扇、硬盘、磁盘驱动器
- 家用电器：洗衣机、冰箱、烤箱

Standard 标准

- EIA 364

UL certification UL认证

- E248993

Material 材料

Part/零件	Material/材料	Finish/电镀	UL Flame retardant/阻燃等级
Housing/主体	PBT	Beige/米色 White/白色 Black/黑色 Blue/蓝色	UL94V-0
Header/板端	PA66	White/白色 Black/黑色 Blue/蓝色	UL94V-0
Terminal/端子	Copper alloy	Au or Sn plated 镀金或锡	-

Production Specifications 产品规格

Current rating 额定电流	3.0 A	Operating Temperature Range:-40° C~+105° (including temperature rise) Operating Humidity Range:20-80% 工作温度范围: -40° C~+105° C(含温升) 工作湿度范围: ≤80%	Storage Teroerature: Operating Humidity: 储存温度: 25±5° C 储存湿度: ≤60%
Voltage rating 额定电压	250V		

Item 项目	Condition 条件	Specification 规格
Insulation Resistance 绝缘电阻	Measured at 1000V DC for 1 minute 测试电压: 1000V DC/1分钟	No less than 1000M Ω 不少于1000MΩ
Withstanding voltage 耐电压	Measured at 1000V AC for 1 minute 测试电压: 1000V AC/1分钟	No breakdown, no discharge, leakage current <0.5mA 无击穿、无放电、漏电流<0.5mA
Contact Resistance 接触电阻	Measured at 100mA and no higher than 20mV 用20 mV DC进行测量	Contact resistance: Initial value/ 20 mo max After environmental tests/ 30 mo max. 接触电阻: 初始值 20 mΩ 以下 测试后 30 mΩ 以下
Vibration Resistance 抗振动	Frequency : 50 ~ 2000 Hz PSD value : 5.35 Gms minimum Duration : 15 minutes/axis Times : Each of three mutually perpendicular planes. 频率: 50 ~ 2000 Hz PSD值: 5.35 Gms 时长: 15分钟/轴 次数: 3次	No electrical discontinuity of 1μsorgreater 试验过程中未发生1μs瞬断现象, 且外观无损伤, 电气性能正常
Humidity (Steady state) 湿度	Temperature : 25~65°C Humidity: 90 ~95% (R.H) Duration : 96 hours 温度: 25~65° C 湿度: 90 ~95% (R.H) 时间: 96小时	Contact resistance: Initial value/ 20 mo max After environmental tests/ 30 mo max. 接触电阻: 初始值 20 mΩ 以下 测试后 30 mΩ 以下
Salt Spray 盐雾	Temperature:35±1°C Humidity:95~98%(R.H) PHValue : 6.5 ~ 7.2 Duration : 12hours 温度: 35±1° C 湿度: 95~98%(R.H) PH值: 6.5~7.2 时间: 24小时	Contact resistance: Initial value/ 20 mo max After environmental tests/ 30 mo max. 接触电阻: 初始值 20 mΩ 以下 测试后 30 mΩ 以下
Durability(Mating/un-mating) 插拔寿命	50 cycles 循环50次	Contact resistance: Initial value/ 20 mo max After environmental tests/ 30 mo max. 接触电阻: 初始值 20 mΩ 以下 测试后 30 mΩ 以下

PCB Layout 印刷电路板布局

Single Row Through-hole type 单排通孔型
(S/T DIP、R/A DIP)

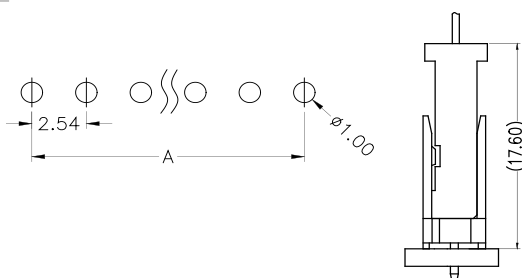

Dual Row Through-hole type 双排通孔型
(S/T DIP、R/A DIP)

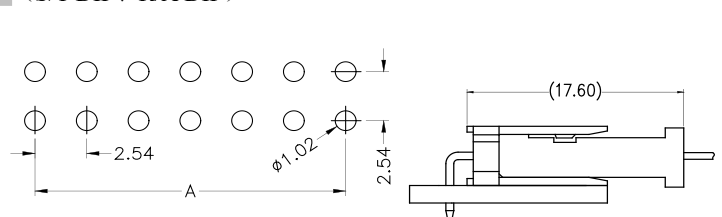

WF2547 Series

Ordering Information 订购信息

Circuit 芯数	Part Number 型号		Dimensions 尺寸 (mm)		Parkage 包装 Q'ty/Bag 只/袋装		Remake 可量产状态	
	S/T DIP		A	B	S/T DIP		S/T DIP	
	Single Row 单排	Dual Row 双排			Single Row 单排	Dual Row 双排	Single Row 单排	Dual Row 双排
2	WF2547-1WS02X01	WF2547-2WS02X01	2.54	5.08	24000	12000	*	*
3	WF2547-1WS03X01	WF2547-2WS03X01	5.08	7.62	18000	12000	*	*
4	WF2547-1WS04X01	WF2547-2WS04X01	7.62	10.16	12000	6000	*	*
5	WF2547-1WS05X01	WF2547-2WS05X01	10.16	12.70	12000	6000	*	*
6	WF2547-1WS06X01	WF2547-2WS06X01	12.70	15.24	7200	4800	*	*
7	WF2547-1WS07X01	WF2547-2WS07X01	15.24	17.78	600	4800	*	*
8	WF2547-1WS08X01	WF2547-2WS08X01	17.78	20.32	600	4800	*	*
9	WF2547-1WS09X01	WF2547-2WS09X01	20.32	22.86	4800	4800	*	*
10	WF2547-1WS10X01	WF2547-2WS10X01	22.86	25.40	4800	1800	*	*
11	WF2547-1WS11X01	WF2547-2WS11X01	25.40	27.94	4200	1800	*	*
12	WF2547-1WS12X01	WF2547-2WS12X01	27.94	30.48	4200	2400	*	*
13	WF2547-1WS13X01	WF2547-2WS13X01	30.48	33.02	4200	2400	*	*
14	WF2547-1WS14X01	WF2547-2WS14X01	33.02	35.56	3600	2400	*	*
15	WF2547-1WS15X01	WF2547-2WS15X01	35.56	38.10	3600	2400	*	*
16	WF2547-1WS16X01	WF2547-2WS16X01	38.10	40.64	3600	2400	*	*
17	WF2547-1WS17X01	WF2547-2WS17X01	40.64	43.18	3600	2400	*	*
18	WF2547-1WS18X01	WF2547-2WS18X01	43.18	45.72	3600	2400	*	*
19	WF2547-1WS19X01	WF2547-2WS19X01	45.72	48.26	3600	1800	*	*
20	WF2547-1WS20X01	WF2547-2WS20X01	48.26	50.80	3600	1800	*	*

Note: * stands for mass production . 注: *代表可量产

Dimensions 尺寸 (Single Row 单排)

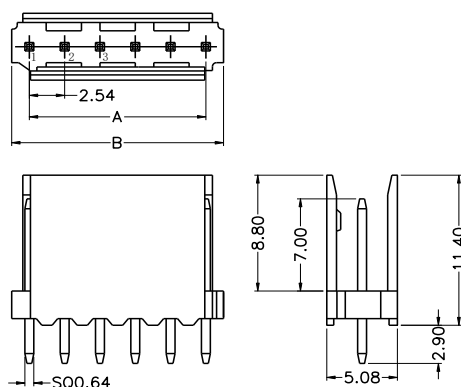

Dimensions 尺寸 (Dual Row 双排)

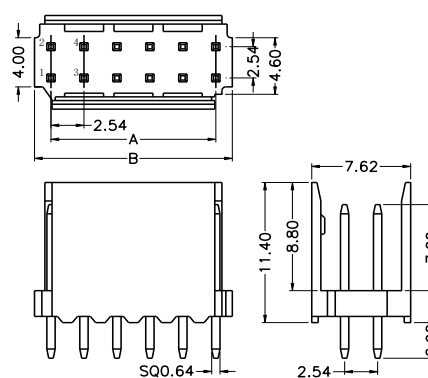

Ordering Information 订购信息

Circuit 芯数	Part Number 型号		Dimensions 尺寸 (mm)		Package 包装 Q'ty/Tube 只/管装		Remake 可量产状态	
	R/A DIP		A	B	R/A DIP		R/A DIP	
	Single Row 单排	Dual Row 双排			Single Row 单排	Dual Row 双排	Single Row 单排	Dual Row 双排
2	WF2547-1WR02XA1	WF2547-2WR02XA1	2.54	5.08	300	120	*	*
3	WF2547-1WR03XA1	WF2547-2WR03XA1	5.08	7.62	150	80	*	*
4	WF2547-1WR04XT1	WF2547-2WR04XT1	7.62	10.16	56	56	*	*
5	WF2547-1WR05XT1	WF2547-2WR05XT1	10.16	12.70	45	45	*	*
6	WF2547-1WR06XT1	WF2547-2WR06XT1	12.70	15.24	37	37	*	*
7	WF2547-1WR07XT1	WF2547-2WR07XT1	15.24	17.78	32	32	*	*
8	WF2547-1WR08XT1	WF2547-2WR08XT1	17.78	20.32	28	28	*	*
9	WF2547-1WR09XT1	WF2547-2WR09XT1	20.32	22.86	25	25	*	*
10	WF2547-1WR10XT1	WF2547-2WR10XT1	22.86	25.40	22	22	*	*
11	WF2547-1WR11XT1	WF2547-2WR11XT1	25.40	27.94	20	20	*	*
12	WF2547-1WR12XT1	WF2547-2WR12XT1	27.94	30.48	18	18	*	*
13	WF2547-1WR13XT1	WF2547-2WR13XT1	30.48	33.02	17	17	*	*
14	WF2547-1WR14XT1	WF2547-2WR14XT1	33.02	35.56	16	16	*	*
15	WF2547-1WR15XT1	WF2547-2WR15XT1	35.56	38.10	14	14	*	*
16	WF2547-1WR16XT1	WF2547-2WR16XT1	38.10	40.64	13	13	*	*
17	WF2547-1WR17XT1	WF2547-2WR17XT1	40.64	43.18	12	12	*	*
18	WF2547-1WR18XT1	WF2547-2WR18XT1	43.18	45.72	12	12	*	*
19	WF2547-1WR19XT1	WF2547-2WR19XT1	45.72	48.26	11	11	*	*
20	WF2547-1WR20XT1	WF2547-2WR20XT1	48.26	50.80	10	10	*	*

Note: * stands for mass production . 注: *代表可量产

Note: 2~3P are Tray 注: 2~3P为真空盒

Dimensions 尺寸 (Single Row 单排)

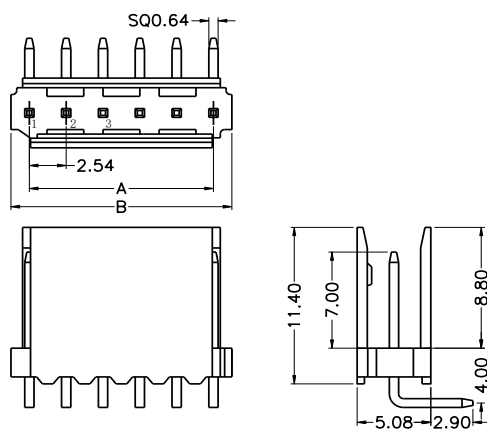

Dimensions 尺寸 (Dual Row 双排)

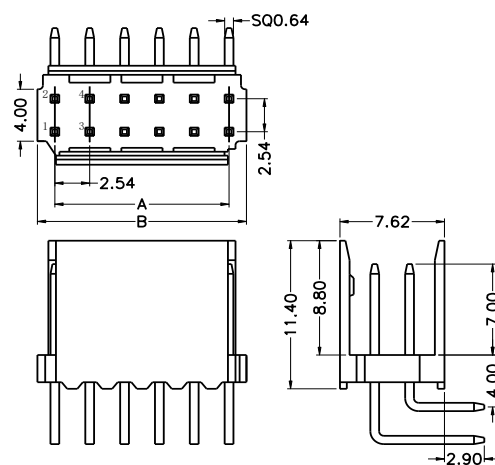

WF2547 Series

Ordering Information 订购信息

Circuit 芯数	Part number 型号		Dimensions 尺寸 (mm)		Package 包装 Q'ty/Bag 只/袋装		Remake 可量产状态	
	Single Row 单排	Dual Row 双排	A	B	Single Row 单排	Dual Row 双排	Single Row 单排	Dual Row 双排
2	WF2547-1H02X01	WF2547-2H02X01	2.54	5.08	3000	1000	*	*
3	WF2547-1H03X01	WF2547-2H03X01	5.08	7.62	2500	1000	*	*
4	WF2547-1H04X01	WF2547-2H04X01	7.62	10.16	200	1000	*	*
5	WF2547-1H05X01	WF2547-2H05X01	10.16	12.70	200	1000	*	*
6	WF2547-1H06X01	WF2547-2H06X01	12.70	15.24	1500	1000	*	*
7	WF2547-1H07X01	WF2547-2H07X01	15.24	17.78	100	800	*	*
8	WF2547-1H08X01	WF2547-2H08X01	17.78	20.32	100	700	*	*
9	WF2547-1H09X01	WF2547-2H09X01	20.32	22.86	100	500	*	*
10	WF2547-1H10X01	WF2547-2H10X01	22.86	25.40	800	500	*	*
11	WF2547-1H11X01	WF2547-2H11X01	25.40	27.94	800	400	*	*
12	WF2547-1H12X01	WF2547-2H12X01	27.94	30.48	800	400	*	*
13	WF2547-1H13X01	WF2547-2H13X01	30.48	33.02	800	400	*	*
14	WF2547-1H14X01	WF2547-2H14X01	33.02	35.56	600	400	*	*
15	WF2547-1H15X01	WF2547-2H15X01	35.56	38.10	500	400	*	*
16	WF2547-1H16X01	WF2547-2H16X01	38.10	40.64	500	350	*	*
17	WF2547-1H17X01	WF2547-2H17X01	40.64	43.18	400	350	*	*
18	WF2547-1H18X01	WF2547-2H18X01	43.18	45.72	400	300	*	*
19	WF2547-1H19X01	WF2547-2H19X01	45.72	48.26	350	200	*	*
20	WF2547-1H20X01	WF2547-2H20X01	48.26	50.80	350	200	*	*

Note: * stands for mass production . 注: *代表可量产

Dimensions 尺寸 (Single Row 单排)

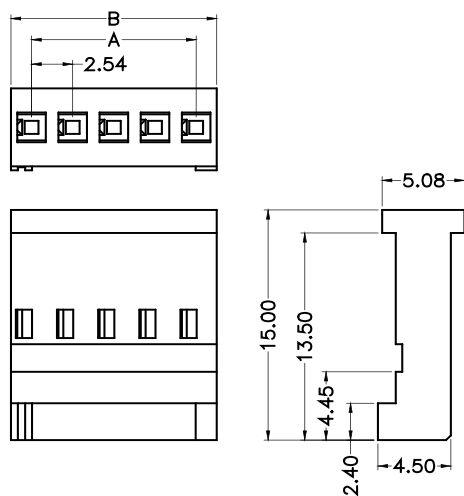

Dimensions 尺寸 (Dual Row 双排)

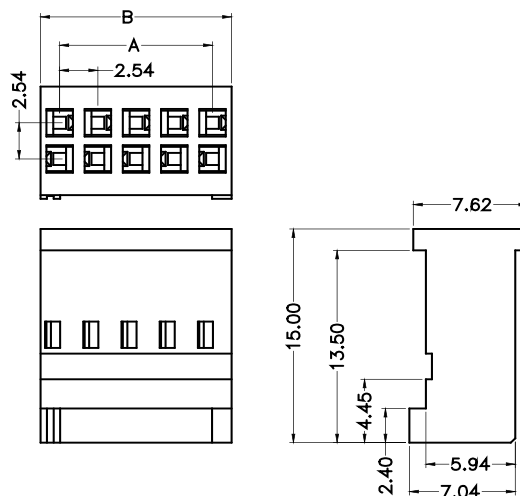

Ordering Information 订购信息

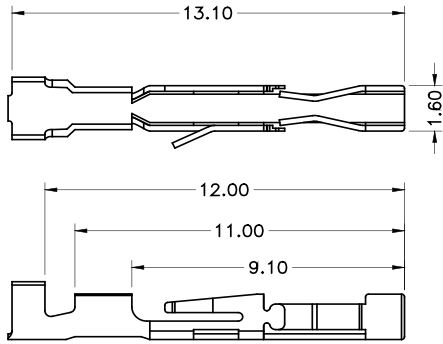

型号 Model number	材料 Material	电镀 Plating	导线范围 Wire Range
WF2547-TBSN01	Brass	Tin	AWG#22~#28
WF2547-TPSN01	Phosphor Bronze	Tin	AWG#22~#28

Terminal Crimp specification 端子压接规范

型号 Model number	电线类型 Wire type	电线规格 Wire size	线缆 OD (mm) Cable OD (mm)	剥线长度 (mm) Strip length (mm)	导体铆压 (A-A) Conductor crimp			绝缘体铆压 (B-B) Insulation crimp	
					压接宽度CB1 Crimping width CB1±0.03mm	压接宽度CBm1 Crimping height CBm1+0.05mm	压接高度 Crimping height CH1±0.03mm	压接宽度CBm2 Crimping width CBm2±0.05mm	压接高度CH2 Crimping width CH2±0.08mm
WF2547-TXXX01	UL 3266	22 AWG	1.60	3.00±0.15mm	1.21	1.25	0.44	1.65	1.59
	UL 1569	24 AWG	1.40		1.20	1.25	0.77	1.66	1.54
	UL 1061	26 AWG	0.90		1.21	1.20	0.70	1.53	1.45
	UL 1007	28 AWG	1.20		1.18	1.24	0.67	1.53	1.29

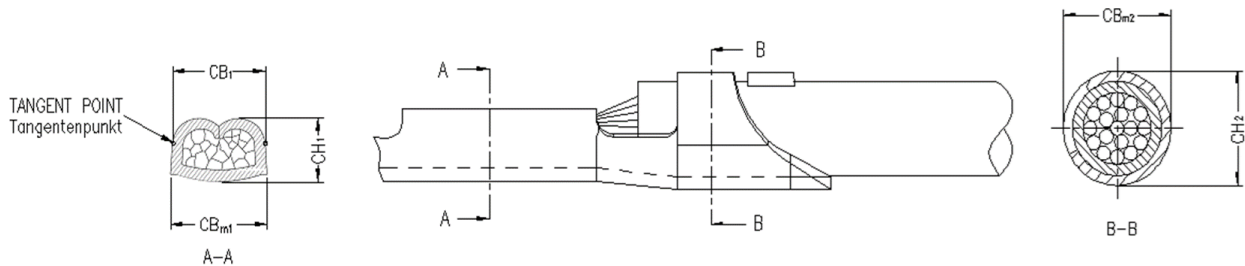

WF2547 Series

Model number allocation 型号命名

WF2547	-	X	XX	XX	X	X	X
(1)		(2)	(3)	(4)	(5)	(6)	(7)
(1) Series (系列): Wafer 2.54mm Series					(5) Color(颜色): W=White、B=Black、U=Blue		
(2) number of Rows(排数): 1=Single Row 2=Dual Row				(6) Packing(包装): 0=PE Bag、T=Tuble			
(3) Terminal type(端子形态): WS=S/T DIP WR=R/A DIP				(7) Internal code(流水码)			
(4) Circuit(位数): 02=2.....20=20P							

WF2547	-	X	H	XX	X	0	1
(1)		(2)	(3)	(4)	(5)	(6)	(7)
(1) Series (系列): Wafer 2.50mm Series					(5) Color(颜色): W=White、B=Black、U=Blue		
(2) Number of Rows(排数): 1=Single Row 2=Dual Row				(6) Packing(包装): 0=PE Bag			
(3) Product type(产品类型): H=Crimp Type Housing				(7) Internal code(流水码)			
(4) Circuit(位数): 02=2.....20=20P							

Contact Us 联系我们

维峰电子股份有限公司(总部)
WCON ELECTRONICS CO.,LTD(HQ)
地址:广东省东莞市虎门镇大宁文明路15号
Add :No.15,Wenming Road,Daning Community, Humen Town,
Dongguan, Guangdong.523930, China

昆山维康电子有限公司
KUNSHAN WCON ELECTRONICIS CO.,LTD(East of China)
地址:昆山市千灯镇汶浦中路169号
Add : No.169, WenPu Middle Road, QianDeng Town, Kunshan
City, Jiangsu Province, China

合肥维峰电子有限公司
HEFEI WCON ELECTRONICIS CO.,LTD
地址:安徽合肥市高新技术开发区绿城科技园E栋2楼
Add : 2F, Building E, Greentown Science Park,High-tech Develop-
ment Zone, Hefei, Anhui,China

维康电子(泰国)有限公司
WCON ELECTRONICS (Thailand) CO.,LTD
地址:泰国巴真武里府西玛铺县华瓦区洛加纳工业园
Add: VG3C+H57, Hua Wa, Si Maha Phot District, Prachin Buri
25140, Thailand

销售联系方式 Sales Contacts

国际客户部 International Sales Department
salesdg01@wcon.com
salesdg05@wcon.com

大客户专线 Key Account Line
华南: salesdg28@wcon.com
华东: salesks@wcon.com

中小客户专线 Small and Medium-sized Account Line
华南: salesdg10@wcon.com
华东: salesks01@wcon.com

网络销售 Online sales
salesdg26@wcon.com



Official Website



Product e-catalog



WeChat Public#



TikTok Public#