

Two-point contact
两点接触

Overview

WF2001 is a 2.0mm pitch wire to board connector, the product has both high density, high performance, high integration and other advantages, can effectively ensure the stability of the signal transmission and integrity, the board end to provide horizontal and vertical direction of the board mounting, to meet the customer's different angles of the insertion of the adapter.

Features and Benefits

- Small size and high integration
- Mis-insertion-proof design to avoid mis-insertion effectively
- Convex point lock design enhances interoperability stability
- board end has various shapes and can meet the plug-in needs of customers in various occasions

Product Applications

- Industrial control and automation
- Equipment monitoring instrument

Standard 标准

- EIA 364

概述

WF2001是一款2.0mm间距线到板连接器，产品兼具高密度、高性能，高集成等优点，能有效确保信号传输的稳定性以及完整性，板端提供水平及垂直方向贴板安装，满足客户不同角度对插适配。

产品特点

- 产品体积小，集成度高
- 防错插设计、有效避免错插
- 凸点锁扣设计，增强互配稳定性
- 板端形态多样，可满足客户各种场合的对插需求

应用领域

- 工业控制与自动化
- 设备监控仪器

UL certification UL认证

- E248993

Material 材料

Part/零件	Material/材料	Finish/电镀	UL Flame retardant/阻燃等级
Housing/主体	PA66	White/白色	UL94V-0
Header/板端	PA66/PA46	White/白色 Black/黑色 Beige/米色 Natural/本色	UL94V-0
Terminal/端子	phosphor bronze 磷铜 (C5191)	Tin plated 镀锡	-

Production Specifications 产品规格

Current rating 额定电流	2.0 A	Operating Temperature Range:-40° C~+105° (including temperature rise) Operating Humidity Range:20-80% 工作温度范围: -40° C~+105° C(含温升) 工作湿度范围: ≤80%	Storage Teroerature: Operating Humidity: 储存温度: 25±5° C 储存湿度: ≤60%
Voltage rating 额定电压	100V		

Item 项目	Condition 条件	Specification 规格
Insulation Resistance 绝缘电阻	Measured at 500V DC for 1 minute 测试电压: 500V DC/1分钟	No less than 1000M Ω 不少于1000MΩ
Withstanding voltage 耐电压	Measured at 500V AC for 1 minute 测试电压: 500V AC/1分钟	No breakdown, no discharge, leakage current <0.5mA 无击穿、无放电、漏电流<0.5mA
Contact Resistance 接触电阻	Measured at 100mA and no higher than 20mV 用20 mV DC进行测量	Contact resistance: Initial value/ 20 mo max After environmental tests/ 30 mo max. 接触电阻: 初始值 20 mΩ 以下 测试后 30 mΩ 以下
Vibration Resistance 抗振动	Frequency : 50 ~ 2000 Hz PSD value : 5.35Gms minimum Duration : 15 minutes/axis Times : Each of three mutually perpendicular planes. 频率: 50 ~ 2000 Hz PSD 值: 5.35Gms minimum 时长: 15分钟/轴	No electrical discontinuity of 1μsorgreater 试验过程中未发生1μs瞬断现象, 且外观无损伤, 电气性能正常
Humidity (Steady state) 湿度	Temperature : 25~65°C Humidity: 90 ~95% (R.H) Duration : 96 hours 温度: 25~65° C 湿度: 90 ~95% (R.H) 时间: 96小时	Contact resistance: Initial value/ 20 mo max After environmental tests/ 30 mo max. 接触电阻: 初始值 20 mΩ 以下 测试后 30 mΩ 以下
Salt Spray 盐雾	Temperature:35#2°C Humidity:95~98%(R.H) PHValue : 6.5 ~ 7.2 Duration : 24hours 温度: 35±2° C 湿度: 95~98%(R.H) PH值: 6.5~7.2 时间: 24小时	Contact resistance: Initial value/ 20 mo max After environmental tests/ 30 mo max. 接触电阻: 初始值 20 mΩ 以下 测试后 30 mΩ 以下
Durability(Mating/un-mating) 插拔寿命	50 cycles 循环50次	Contact resistance: Initial value/ 20 mo max After environmental tests/ 30 mo max. 接触电阻: 初始值 20 mΩ 以下 测试后 30 mΩ 以下

PCB Layout 印刷电路板布局

(S/T)SMT type 表面贴装型

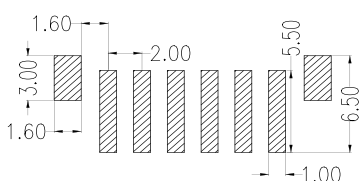

(R/A)SMT type 表面贴装型

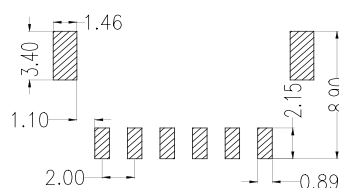

R/A DIP type 插孔装型
S/T DIP type 插孔装型

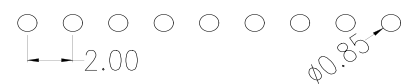

WF2001 Series

Dimensions 尺寸 (R/A SMT)

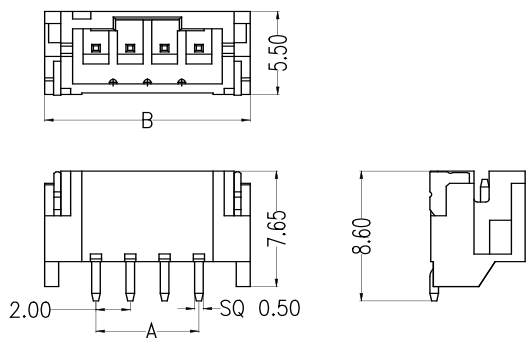

Assembly Schematic 装配示意

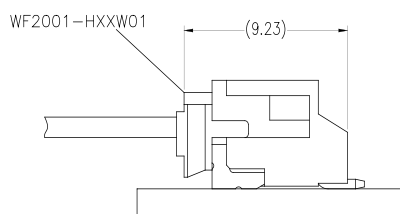

Ordering Information 订购信息

Circuit 芯数	Part number 型号	Dimensions 尺寸 (mm)		Package 包装 Q'ty/Bag 只/袋装	Remake 可量产状态
		A	B		
2	WF2001-WZ02XXXX1	2.0	8.0	700	*
3	WF2001-WZ03XXXX1	4.0	10.0	700	*
4	WF2001-WZ04XXXX1	6.0	12.0	700	*
5	WF2001-WZ05XXXX1	8.0	14.0	700	*
6	WF2001-WZ06XXXX1	10.0	16.0	700	*
7	WF2001-WZ07XXXX1	12.0	18.0	700	*
8	WF2001-WZ08XXXX1	14.0	20.0	700	*
9	WF2001-WZ09XXXX1	16.0	22.0	700	*
10	WF2001-WZ10XXXX1	18.0	24.0	700	*
11	WF2001-WZ11XXXX1	20.0	26.0	700	*
12	WF2001-WZ12XXXX1	22.0	28.0	700	*
13	WF2001-WZ13XXXX1	24.0	30.0	700	*
14	WF2001-WZ14XXXX1	26.0	32.0	700	*
15	WF2001-WZ15XXXX1	28.0	34.0	700	*
16	WF2001-WZ16XXXX1	30.0	36.0	700	*

Note: * stands for mass production . 注: *代表可量产

Dimensions 尺寸 (S/T SMT)

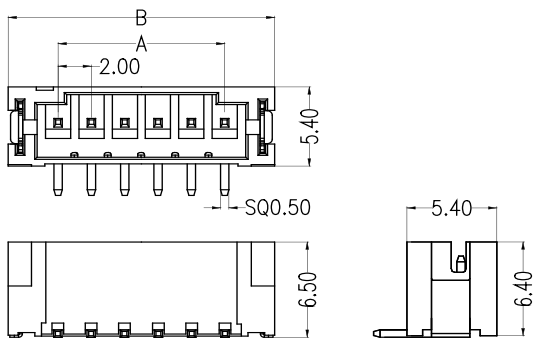

Assembly Schematic 装配示意

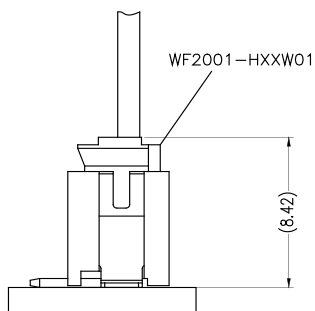

Ordering Information 订购信息

Circuit 芯数	Part number 型号	Dimensions		Package 包装 Q'ty/Reel 只/卷装	Remake 可量产状态
		A	B		
2	WF2001-WM02XXEX1	2.0	7.95	450	*
3	WF2001-WM03XXEX1	4.0	9.95	450	*
4	WF2001-WM04XXEX1	6.0	11.95	450	*
5	WF2001-WM05XXEX1	8.0	13.95	450	*
6	WF2001-WM06XXEX1	10.0	15.95	450	*
7	WF2001-WM07XXEX1	12.0	17.95	450	*
8	WF2001-WM08XXEX1	14.0	19.95	450	*
9	WF2001-WM09XXEX1	16.0	21.95	450	*
10	WF2001-WM10XXEX1	18.0	23.95	450	*
11	WF2001-WM11XXEX1	20.0	25.95	450	*
12	WF2001-WM12XXEX1	22.0	27.95	450	*
13	WF2001-WM13XXEX1	24.0	29.95	450	*
14	WF2001-WM14XXEX1	26.0	31.95	450	*
15	WF2001-WM15XXEX1	28.0	33.95	450	*
16	WF2001-WM16XXEX1	30.0	35.95	450	*

Note: * stands for mass production . 注: *代表可量产

Dimensions 尺寸 (S/T DIP)

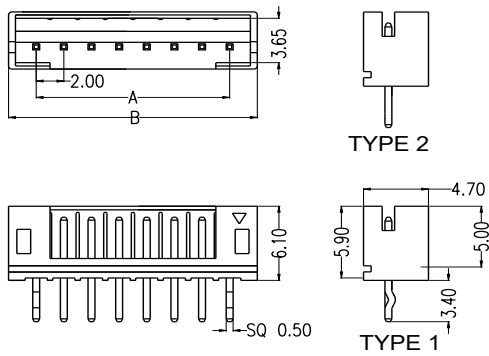

Assembly Schematic 装配示意

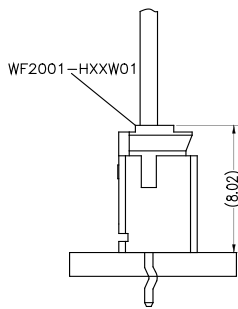

Ordering Information 订购信息

Circuit 芯数	Part number 型号		Dimensions 尺寸 (mm)		Package 包装 Q'ty/Bag 只/袋装	Remake 可量产 状态
	TYPE 1	TYPE 2	A	B		
2	WF2001-WS02XXXX1	WF2001-WS02XXXX2	2.00	6.00	1000	*
3	WF2001-WS03XXXX1	WF2001-WS03XXXX2	4.00	8.00	1000	*
4	WF2001-WS04XXXX1	WF2001-WS04XXXX2	6.00	10.00	1000	*
5	WF2001-WS05XXXX1	WF2001-WS05XXXX2	8.00	12.00	1000	*
6	WF2001-WS06XXXX1	WF2001-WS06XXXX2	10.00	14.00	1000	*
7	WF2001-WS07XXXX1	WF2001-WS07XXXX2	12.00	16.00	1000	*
8	WF2001-WS08XXXX1	WF2001-WS08XXXX2	14.00	18.00	1000	*
9	WF2001-WS09XXXX1	WF2001-WS09XXXX2	16.00	20.00	1000	*
10	WF2001-WS10XXXX1	WF2001-WS10XXXX2	18.00	22.00	1000	*
11	WF2001-WS11XXXX1	WF2001-WS11XXXX2	20.00	24.00	1000	*
12	WF2001-WS12XXXX1	WF2001-WS12XXXX2	22.00	26.00	1000	*
13	WF2001-WS13XXXX1	WF2001-WS13XXXX2	24.00	28.00	1000	*
14	WF2001-WS14XXXX1	WF2001-WS14XXXX2	26.00	30.00	1000	*
15	WF2001-WS15XXXX1	WF2001-WS15XXXX2	28.00	32.00	1000	*
16	WF2001-WS16XXXX1	WF2001-WS16XXXX2	30.00	34.00	1000	*
17	WF2001-WS17XXXX1	WF2001-WS17XXXX2	32.00	36.00	1000	*
18	WF2001-WS18XXXX1	WF2001-WS18XXXX2	34.00	38.00	1000	*
19	WF2001-WS19XXXX1	WF2001-WS19XXXX2	36.00	40.00	1000	*
20	WF2001-WS20XXXX1	WF2001-WS20XXXX2	38.00	42.00	1000	*

Note: * stands for mass production . 注: *代表可量产

Dimensions 尺寸 (R/A DIP)

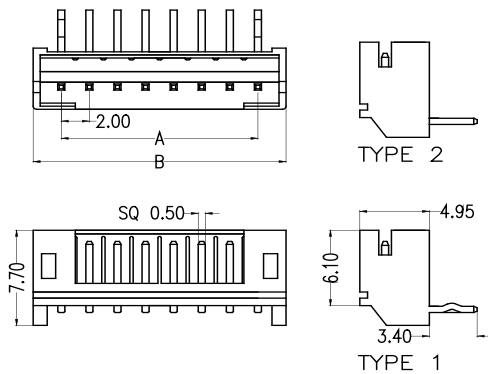

Assembly Schematic 装配示意

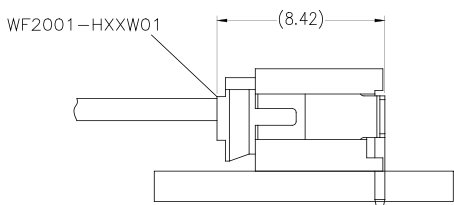

Ordering Information 订购信息

Circuit 芯数	Part number 型号		Dimensions 尺寸 (mm)		Package 包装 Q'ty/Bag 只/袋装	Remake 可量产 状态
	TYPE 1	TYPE 2	A	B		
2	WF2001-WR02XXXX1	WF2001-WR02XXXX2	2.00	6.00	1000	*
3	WF2001-WR03XXXX1	WF2001-WR03XXXX2	4.00	8.00	1000	*
4	WF2001-WR04XXXX1	WF2001-WR04XXXX2	6.00	10.00	1000	*
5	WF2001-WR05XXXX1	WF2001-WR05XXXX2	8.00	12.00	1000	*
6	WF2001-WR06XXXX1	WF2001-WR06XXXX2	10.00	14.00	1000	*
7	WF2001-WR07XXXX1	WF2001-WR07XXXX2	12.00	16.00	1000	*
8	WF2001-WR08XXXX1	WF2001-WR08XXXX2	14.00	18.00	1000	*
9	WF2001-WR09XXXX1	WF2001-WR09XXXX2	16.00	20.00	1000	*
10	WF2001-WR10XXXX1	WF2001-WR10XXXX2	18.00	22.00	1000	*
11	WF2001-WR11XXXX1	WF2001-WR11XXXX2	20.00	24.00	1000	*
12	WF2001-WR12XXXX1	WF2001-WR12XXXX2	22.00	26.00	1000	*
13	WF2001-WR13XXXX1	WF2001-WR13XXXX2	24.00	28.00	1000	*
14	WF2001-WR14XXXX1	WF2001-WR14XXXX2	26.00	30.00	1000	*
15	WF2001-WR15XXXX1	WF2001-WR15XXXX2	28.00	32.00	1000	*
16	WF2001-WR16XXXX1	WF2001-WR16XXXX2	30.00	34.00	1000	*
17	WF2001-WR17XXXX1	WF2001-WR17XXXX2	32.00	36.00	1000	*
18	WF2001-WR18XXXX1	WF2001-WR18XXXX2	34.00	38.00	1000	*
19	WF2001-WR19XXXX1	WF2001-WR19XXXX2	36.00	40.00	1000	*
20	WF2001-WR20XXXX1	WF2001-WR20XXXX2	38.00	42.00	1000	*

Note: * stands for mass production . 注: *代表可量产

WF2001 Series

Dimensions 尺寸

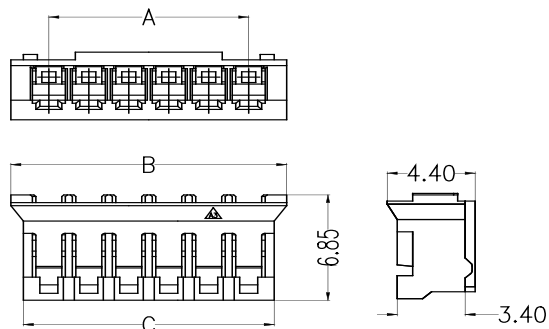

Adaptor Terminal 适配端子

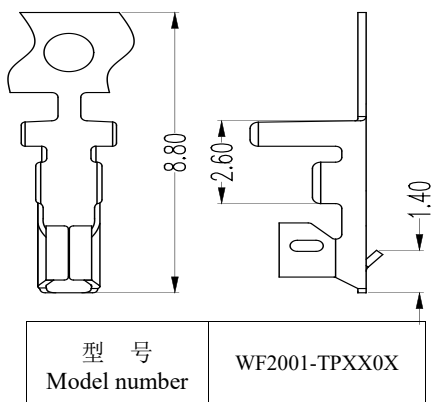

Ordering Information 订购信息

Circuit 芯数	Part number 型号	Dimensions 尺寸 (mm)			Package 包装 Q'ty/Bag 只/袋装	Remake 可量产状态
		A	B	C		
2	WF2001-H02X01	2.00	5.80	4.55	1000	*
3	WF2001-H03X01	4.00	7.80	6.55	1000	*
4	WF2001-H04X01	6.00	9.80	8.55	1000	*
5	WF2001-H05X01	8.00	11.80	10.55	1000	*
6	WF2001-H06X01	10.00	13.80	12.55	1000	*
7	WF2001-H07X01	12.00	15.80	14.55	1000	*
8	WF2001-H08X01	14.00	17.80	16.55	1000	*
9	WF2001-H09X01	16.00	19.80	18.55	1000	*
10	WF2001-H10X01	18.00	21.80	20.55	1000	*
11	WF2001-H11X01	20.00	23.80	22.55	1000	*
12	WF2001-H12X01	22.00	25.80	24.55	1000	*
13	WF2001-H13X01	24.00	27.80	26.55	1000	*
14	WF2001-H14X01	26.00	29.80	28.55	1000	*
15	WF2001-H15X01	28.00	31.80	30.55	1000	*
16	WF2001-H16X01	30.00	33.80	32.55	800	*

Note: * stands for mass production . 注: *代表可量产

Terminal Crimp specification 端子压接规范

型号 Model number	电线类型 Wire type	电线规格 Wire size	线缆 OD (mm) Cable OD (mm)	剥线长度 (mm) Strip length (mm)	导体铆压 (A-A) Conductor crimp			绝缘体铆压 (B-B) Insulation crimp	
					压接宽度CB1 Crimping width CB1±0.03mm	压接宽度CBm1 Crimping height CBm1+0.05mm	压接高度 Crimping height CH1±0.03mm	压接宽度CBm2 Crimping width CBm2±0.05mm	压接高度CH2 Crimping width CH2±0.08mm
WF2001-TPXX01	UL 1007	26AWG	1.30±0.1	2.40±0.1	1.20	1.20	0.72	1.45	1.61
	UL 1007	24AWG	1.40±0.1		1.20	1.20	0.81	1.35	1.53
WF2001-TPXX02	UL 1007	26AWG	1.50±0.1		1.20	1.20	0.76	1.45	1.61
	UL 1007	24AWG	1.20±0.1		1.20	1.20	0.83	1.35	1.53
WF2001-TPXX03	UL 1007	30AWG	1.30±0.1		/	/	/	/	/
	UL 1007	28AWG	1.40±0.1		/	/	/	/	/

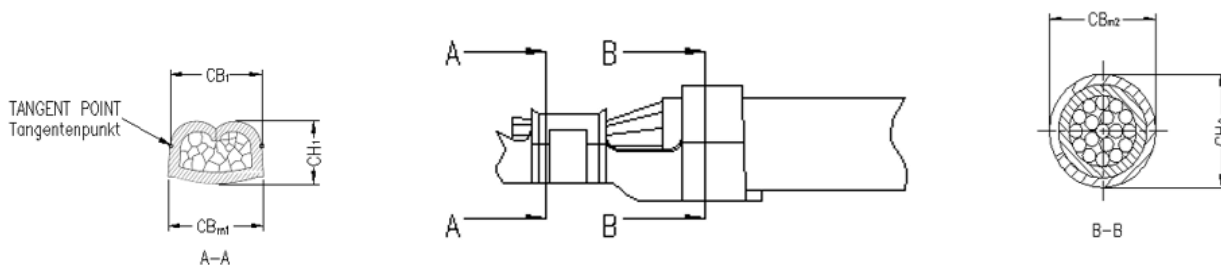

Model number allocation 型号命名 Single Row

WF2001	-	XX	XX	XX	X	X	1
(1)		(2)	(3)	(4)	(5)	(6)	(7)
(1) Series (系列): Wafer 2.00mm Series				(5) Color(颜色): W=White B=Black E=Beige T=Natural			
(2) Terminal type (端子形态): WM=S/T SMT WZ=R/A SMT WS=S/T DIP WR=R/A DIP				(6) Packing (包装): T=Tube 0=PE Bag			
(3) Circuit (位数): 02=2P.....16=16P				(7) Internal code (流水码)			
(4) Contact Plating (电镀):Blank=Tin GX=xx u" Gold SX=xx u" Gold /Tin							

WF2001	-	H	XX	W	0	1
(1)		(2)	(3)	(4)	(5)	(6)
(1) Series (系列): Wafer 2.00mm Series				(4) Color(颜色): W=White		
(2) Product type (产品类型): H=Crimp Type Housing				(5) Packing (包装): 0=PE Bag		
(3) Circuit (位数): 02=2P.....16=16P				(6) Internal code (流水码)		

Contact Us 联系我们

维峰电子股份有限公司(总部)
WCON ELECTRONICS CO.,LTD(HQ)
地址:广东省东莞市虎门镇大宁文明路15号
Add :No.15,Wenming Road,Daning Community, Humen Town, Dongguan, Guangdong,523930, China

昆山维康电子有限公司
KUNSHAN WCON ELECTRONICIS CO.,LTD(East of China)
地址:昆山市千灯镇汶浦中路169号
Add : No.169, WenPu Middle Road, QianDeng Town, Kunshan City, Jiangsu Province, China

合肥维峰电子有限公司
HEFEI WCON ELECTRONICIS CO.,LTD
地址:安徽合肥市高新技术开发区绿城科技园E栋2楼
Add : 2F, Building E, Greentown Science Park,High-tech Development Zone, Hefei, Anhui,China

维康电子(泰国)有限公司
WCON ELECTRONICS (Thailand) CO.,LTD
地址:泰国巴真武里府西玛铺县华瓦区洛加纳工业园
Add: VG3C+H57, Hua Wa, Si Maha Phot District, Prachin Buri 25140, Thailand

销售联系方式 Sales Contacts

国际客户部 International Sales Department
salesdg01@wcon.com
salesdg05@wcon.com

大客户专线 Key Account Line
华南: salesdg28@wcon.com
华东: salesks@wcon.com

中小客户专线 Small and Medium-sized Account Line
华南: salesdg10@wcon.com
华东: salesks01@wcon.com

网络销售 Online sales
salesdg26@wcon.com



Official Website



Product e-catalog



WeChat Public#



TikTok Public#