

# HSF

**NOTES:**

Rated Current: 5.0AMP.(20°C,1\*2P-1\*15P)

3.0AMP.(20°C,1\*16P-1\*40P)  $\triangle A5$

Contact Resistance: 20mΩ Max.

Withstand Voltage: 1000V AC/DC

Insulation Resistance: 1000MΩ Min.

Operation Temperature: -40°C to +125°C(Gold Plating)  $\triangle A5$   
 -40°C to +105°C(Tin Plating)

Contact Material: Copper Alloy

Contact Plating: Au or Sn Over 30u" Min Ni

Insulator Material: PA9T+G.F UL94V-0 BK  $\triangle A3$   $\triangle A5$

## Ordering Information

1125- 1 1 XX XX S XXX C X XX  $\triangle A5$

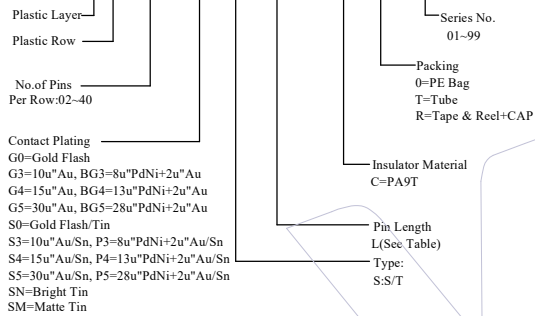

Item	Pin Length	A	B	Mating
Standard	9.0	3.00	3.5	2135/2150T/2157
	9.5		4.0	2145/2150
	10.5		5.0	2168T/2171T
	11.3		5.84	2171/2185X
Standard	8.0	2.0 (THR)	3.5	2135/2150T/2157
	8.5		4.0	2145/2150
	9.5		5.0	2168T/2171T
	10.3		5.84	2171/2185X
Alternate				

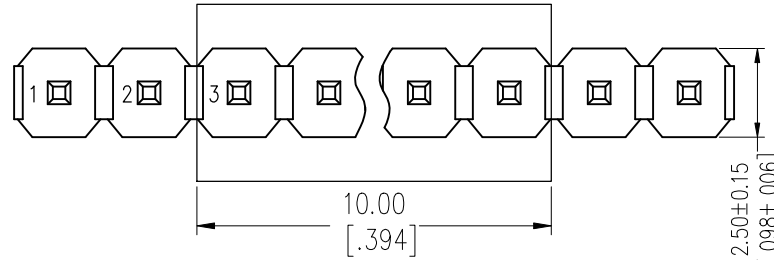

Recommended P.C.B Layout (Top Side)  
 (PCB BOARD TOLERANCE ±0.05)  
 (PCB Thickness: T=1.60mm)

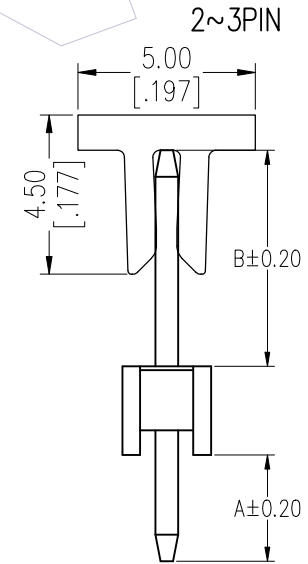
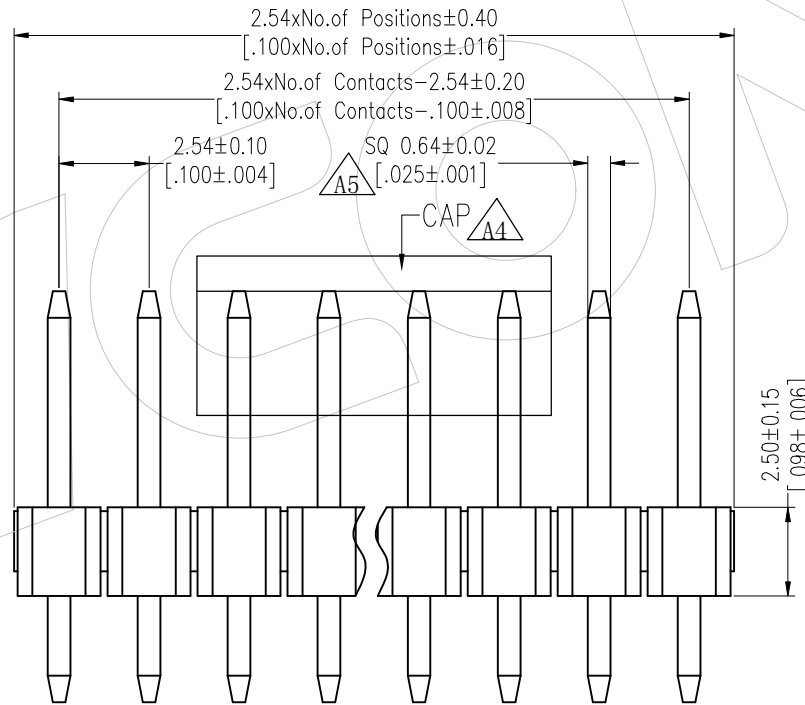
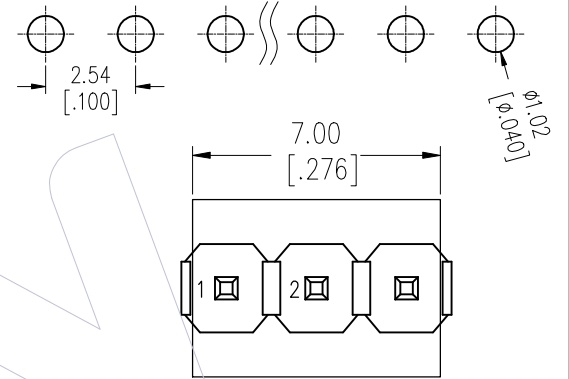

A5	2025/03/06	Standardization Drawing	CP	OPERATION	DRAW	DATE	SCALE	Fit	PART NO. 1125-11XXXXXXCX $\triangle A4$
A4	2021/01/29	Add CAP	DuYing	x.X ± 0.40	CP	2025/03/06	UNIT	mm [inch]	
A3	2018/06/02	Cancel PBT & Modify P/N	Surong Xu	x.XX ± 0.25	CHECK	DATE	SIZE	A4	TITLE: PH2.54 SINGLE ROW S/T H=2.5
A0	2012/05/17	NEW	William Chen	x.XXX ± 0.15	TANG	2025/03/06	SHEET	1/4	
REV	DATE	MODIFICATION DESCRIPTION	CHANGE	Angle ± 3°	APPROVE	DATE	SHEET	1/4	Customer NO.
				DIM TOL	Steven Zhao	2025/03/06	PROJ.		

# WCON

Http: www.wcon.com

WCON-Dongguan Tel: +86 769 85358920 Fax: +86 769 85358915 E-mail: sales@wcon.com  
 WCON-Kunshan Tel: +86 512 57468408 Fax: +86 512 57468468 E-mail: salesks@wcon.com

HSF

# Packing:

PE Bag:

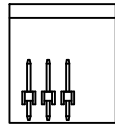

PE Bag

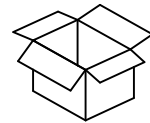

Inner Box

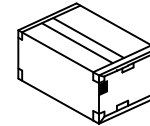

Box

Tube:

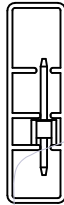

Tube

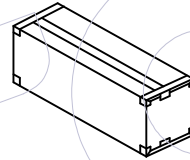

Inner Box

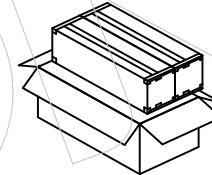

Box

Reel:

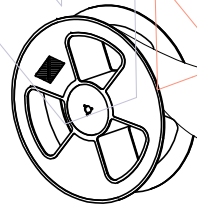

客户安装时拉出方向  
Customer pull out direction

Round

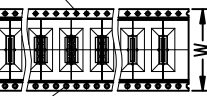

Ellipse

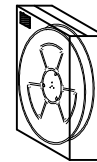

Inner Box

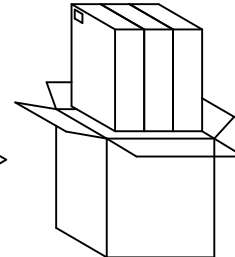

Box (Put in 3 Inner Box)

A5	2025/03/06	Standardization Drawing	CP	OPERATION	DRAW	DATE	SCALE	Fit	PART NO.
A4	2021/01/29	Add CAP	DuYing	X.X ±0.40	CP	2025/03/06	UNIT	mm [inch]	1125-11XXXXXXXCXXX $\triangle$ A4
A3	2018/06/02	Cancel PBT & Modify P/N	Surong Xu	X.XX ±0.25	CHECK	DATE	SIZE	A4	TITLE:
A0	2012/05/17	NEW	William Chen	X.XXX ±0.15	TANG	2025/03/06	SHEET	2/4	PH2.54 SINGLE ROW S/T H=2.5
REV	DATE	MODIFICATION DESCRIPTION	CHANGE	ANGLE	APPROVE	DATE	PROJ.		Customer NO.
				DIM TOL	Steven Zhao	2025/03/06			

**WCON**  
Http: www.wcon.com

WCON-Dongguan Tel: +86 769 85358920 Fax: +86 769 85358915 E-mail: sales@wcon.com	WCON-Kunshan Tel: +86 512 57468408 Fax: +86 512 57468468 E-mail: salesks@wcon.com
---	--

**HSF**

## Packaging Quantity Refers To The Following Table

PINS	Q' ty/Bag L≤10.0	PINS	Q' ty/Bag L≤10.0	PINS	Q' ty/Bag 10.0<L≤16.0	PINS	Q' ty/Bag 10.0<L≤16.0
1	1,000	21	300	1	1,000	21	200
2	1,000	22	300	2	1,000	22	200
3	1,000	23	300	3	1,000	23	200
4	1,000	24	300	4	1,000	24	200
5	1,000	25	300	5	1,000	25	200
6	1,000	26	300	6	1,000	26	200
7	1,000	27	300	7	1,000	27	200
8	1,000	28	300	8	500	28	200
9	1,000	29	300	9	500	29	200
10	500	30	300	10	500	30	200
11	500	31	300	11	500	31	200
12	500	32	300	12	500	32	200
13	500	33	300	13	500	33	200
14	500	34	300	14	500	34	200
15	500	35	300	15	500	35	200
16	500	36	300	16	400	36	200
17	400	37	300	17	400	37	200
18	400	38	300	18	300	38	200
19	400	39	300	19	300	39	200
20	400	40	300	20	150	40	200

W/O CAP

W/O CAP

PINS	Q' ty/Tube	Q' ty/Inner Box	Q' ty/Box	PINS	Q' ty/Tube	Q' ty/Inner Box	Q' ty/Box
4	54	6,480	12,960	23	9	1,080	2,160
5	45	5,400	10,800	24	9	1,080	2,160
6	38	4,560	9,120	25	9	1,080	2,160
7	32	3,840	7,680	26	8	960	1,920
8	27	3,240	6,480	27	8	960	1,920
9	24	2,880	5,760	28	8	960	1,920
10	22	2,640	5,280	29	7	840	1,680
11	20	2,400	4,800	30	7	840	1,680
12	19	2,280	4,560	31	7	840	1,680
13	17	2,040	4,080	32	7	840	1,680
14	16	1,920	3,840	33	6	720	1,440
15	15	1,800	3,600	34	6	720	1,440
16	14	1,680	3,360	35	6	720	1,440
17	13	1,560	3,120	36	6	720	1,440
18	12	1,440	2,880	37	6	720	1,440
19	11	1,320	2,640	38	5	600	1,200
20	11	1,320	2,640	39	5	600	1,200
21	10	1,200	2,400	40	5	600	1,200
22	10	1,200	2,400				

A5	2025/03/06	Standardization Drawing	CP	OPERATION	DRAW	DATE	SCALE	Fit	PART NO.
A4	2021/01/29	Add CAP	DuYing	x.X ±0.40	CP	2025/03/06	UNIT	mm [inch]	1125-11XXXXXXXCXXX
A3	2018/06/02	Cancel PBT & Modify P/N	Surong Xu	x.xx ±0.25	CHECK	DATE	SIZE	A4	TITLE:
A0	2012/05/17	NEW	William Chen	x.xxx ±0.15	TANG	2025/03/06	SHEET	3/4	PH2.54 SINGLE ROW S/T H=2.5
REV	DATE	MODIFICATION DESCRIPTION	CHANGE	Angle ± 3°	APPROVE	DATE	PROJ.		Customer NO.
				DIM TOL	Steven Zhao	2025/03/06			



WCON-Dongguan Tel: +86 769 85358920 Fax: +86 769 85358915 E-mail: sales@wcon.com	WCON-Kunshan Tel: +86 512 57468408 Fax: +86 512 57468468 E-mail: salesks@wcon.com
---	--

**HSF**



## Packaging Quantity Refers To The Following Table

B=3.5/4.0

PINS	W	Q' ty/Reel	Q' ty/Inner Box	Q' ty/Box
2	24	440	1,320	3,960
3	24	440	1,320	3,960
4	24	440	1,320	3,960
5	32	440	880	2,640
6	32	440	880	2,640
7	44	440	880	2,640
8	44	440	880	2,640
9	44	440	880	2,640
10	44	440	880	2,640
11	56	440	440	1,320
12	56	440	440	1,320
13	56	440	440	1,320
14	56	440	440	1,320
15	56	440	440	1,320
16	72	440	440	1,320
17	72	440	440	1,320
18	72	440	440	1,320
19	72	440	440	1,320
20	72	440	440	1,320
21	72	440	440	1,320
22	88	440	440	1,320
23	88	440	440	1,320
24	88	440	440	1,320
25	88	440	440	1,320
26	88	440	440	1,320
27	88	440	440	1,320

B=5.0/5.84

PINS	W	Q' ty/Reel	Q' ty/Inner Box	Q' ty/Box
2	24	290	870	2,610
3	24	290	870	2,610
4	32	290	580	1,740
5	32	390	780	2,340
6	44	290	580	1,740
7	44	390	780	2,340
8	44	390	780	2,340
9	44	290	580	1,740
10	56	290	290	870
11	56	290	290	870
12	56	290	290	870
13	56	290	290	870
14	56	290	290	870
15	72	290	290	870
16	72	290	290	870
17	72	290	290	870
18	72	290	290	870
19	72	290	290	870
20	72	290	290	870
21	88	290	290	870
22	88	290	290	870
23	88	290	290	870
24	88	290	290	870
25	88	290	290	870
26	88	290	290	870
27	88	290	290	870

A5	2025/03/06	Standardization Drawing	CP	OPERATION	DRAW	DATE	SCALE	Fit	PART NO.
A4	2021/01/29	Add CAP	DuYing	x.X ±0.40	CP	2025/03/06	UNIT	mm [inch]	1125-11XXXXXXXCXXX 
A3	2018/06/02	Cancel PBT & Modify P/N	Surong Xu	x.xx ±0.25	CHECK	DATE	SIZE	A4	TITLE:
A0	2012/05/17	NEW	William Chen	x.xxx ±0.15	TANG	2025/03/06	SHEET	4/4	PH2.54 SINGLE ROW S/T H=2.5
REV	DATE	MODIFICATION DESCRIPTION	CHANGE	Angle ± 3°	APPROVE	DATE	PROJ.		Customer NO.
				DIM TOL	Steven Zhao	2025/03/06			



WCON-Dongguan Tel: +86 769 85358920 Fax: +86 769 85358915 E-mail: sales@wcon.com	WCON-Kunshan Tel: +86 512 57468408 Fax: +86 512 57468468 E-mail: salesks@wcon.com
---	--