

HSF

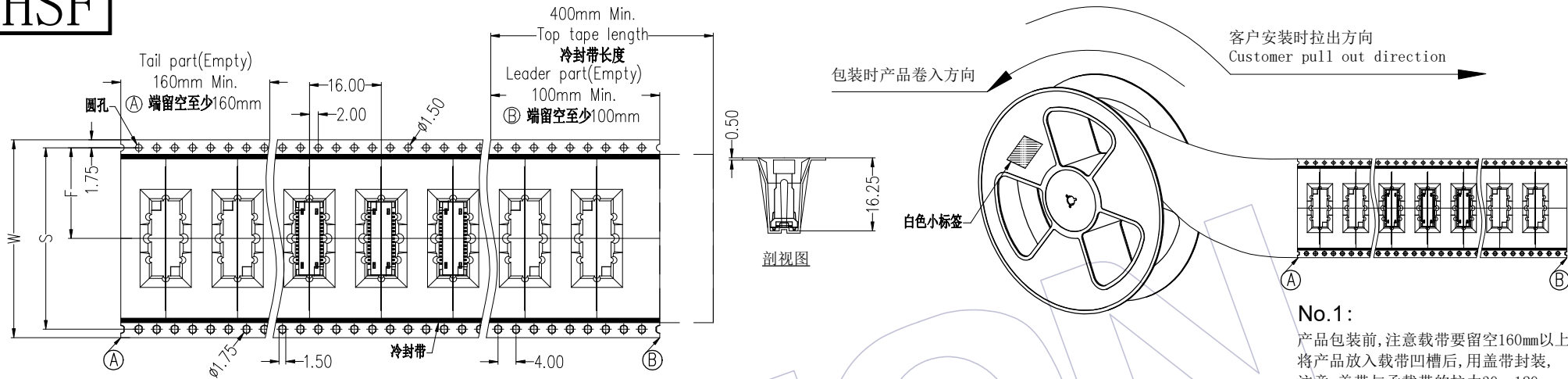

No.1:
产品包装前,注意载带要留空160mm以上
将产品放入载带凹槽后,用盖带封装,
注意:盖带与承载带的拉力30g-120g

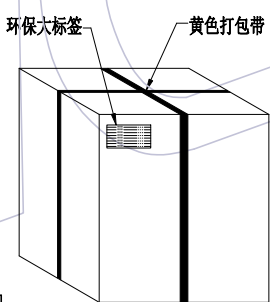

外箱: CTN-18K

No.4:
封箱, 打包, 贴标签。

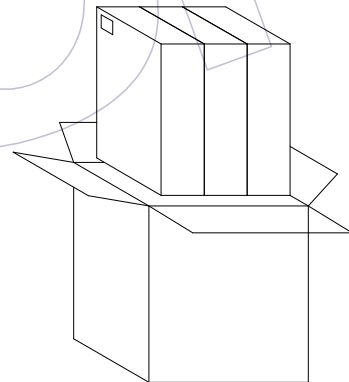

No.3:
将内箱装入外箱(3内箱/外箱)
注意统一标签方向

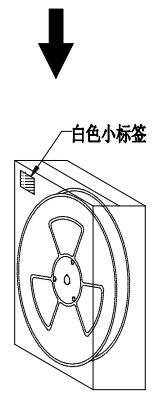

内箱: CTN-18E

No.2:
将卷盘套上防水袋,
放入1包干燥剂,
真空机封口后装入内箱,
用封箱胶封装好,并贴上标签。

PIN	载带料号	W	S	F	PCS/Reel	PCS/内箱	PCS/外箱
30	TR3618-MN030M15501	44.0±0.30	40.40±0.15	20.20±0.15	210	420	1260
40	TR3618-MN040M15501	44.0±0.30	40.40±0.15	20.20±0.15	210	420	1260
60	TR3618-MN060M15501	56.0±0.30	52.40±0.15	26.20±0.15	210	210	630
80	TR3618-MN080M15501	72.0±0.30	68.40±0.15	34.20±0.15	210	210	630

变更 记录								工程图 ENGINEERING	绘图 DRAW	苏珊	2022/09/28	SCALE	FIT	WCON	
								X.X	±0.30	设计 DESIGN			UNIT		
									X.XX	±0.20	审核 CHECK			SIZE	A4
									X.XXX	±0.10	核准 APPROVE			SHEET	1/1
	A0	2022/09/28			NEW	-----	-----	Angle	± 2'	核准 APPROVE			PROJ.	品名 TITLE:	料号 PART NO.
版次 REV	日期 DATE	变更说明 MODIFICATION DESCRIPTION				变更 CHANGE	核准 APPROVE	DIM	TOL			品名 TITLE:		0.8mm BTB直立式公座, SMT Type, W/T CAP H=14.55mm 卷装规范	